

SHOW RULE CHANGES

The following proposed changes to the CPOA Association's Official Show Rules are presented here for your consideration. If the Home Office does not receive a significant number of members opposed to the changes within thirty days they will become effective after that time has expired.

1. Change POA to CPOA where we required.

2. EXHIBITORS ARE RESPONSIBLE FOR KNOWLEDGE OF ALL SHOW RULES - **Delete Section and replace with:**

The following rules were adopted by the Canadian Pony of the Americas Association and apply to all Pony of the Americas shown in CPOA Approved Point Shows and/or Classes. Specific rules for a given class take precedence over the general rules, if different. All rules must be observed by all exhibitors, Show Committees, Provincial clubs, the National Organization, Judges, Ringmen, and any other person in any way connected with sponsoring CPOA Association approved shows, exhibiting in them, or judging them, in order to have uniform rules to effect the utmost fairness to all, to obtain a definite system and to give the exhibitors the proper credit.

A judge's decision, representing his individual preference, is not protestable unless it is alleged to be a violation of the rules.

The show committee of every CPOA show shall have the obligation and final authority in all matters pertaining to the show, unless they are in direct violation of the rules.

Notification of Show Rule changes are to be published in the CPOA Association Official Magazine and the changes will be accepted unless the majority of the members are in disagreement with these changes. Said response to the Show Rule changes must be received within 30 days after they are printed in the magazine.

Any fees or charges listed in these rules are subject to change without notice.

3. QUALITY OF POA - **delete section.**

4. GAITS OF CPOA - **amend B.** as follows:

B. The Western jog trot should be soft, relaxed, and quiet with a definite two beat gait. At no time should it resemble a running walk, nor should it be rough or stilted. The speed and stride should be compatible with the pony's size. The English trot should be a free-moving, elastic and ground covering stride. Excessive knee or hock action is at no time desirable. Quick, short strides should be penalized.

5. SHOWS - HALTER AND PERFORMANCE - **amend last line to:** Ponies two years and under cannot be ridden.

6. REGISTRATION - **Delete entire section and replace with:**

CERTIFICATION

All CPOA ponies exhibited THAT ARE OVER SIX YEARS OF AGE MUST BE INSPECTED and THEIR CERTIFICATE UPDATED before they are able to show as a 7 year old.

The owner is required to produce the pony's certificate or a photo copy of both sides of the certificate at every show or a notice from the Home Office that enables the pony to show due to processing of paperwork. It is recommended that a photo copy of both sides of the certificate accompany the entry form for a show.

The pony's name must be identical at any show to the one shown on the pedigree. The pony when entered in any show must use the same name and certification number that appears on its certificate.

Only ponies with a CPOA or POAC certificate are permitted to show in CPOA point approved classes. The show committee will be responsible to ensure that every pony that enters a CPOA point approved class has proven by it's certificate that it is eligible to show. There will be disciplinary action taken by the Board of Directors to an appointed National Hearing Committee if a pony that is not certified is permitted entry into an approved CPOA class. An appeal may be made to the Board of Directors and their decision shall be final.

Ponies registered with the Pony of the Americas Inc. are permitted to show in CPOA point approved shows but will not receive CPOA national points when they are showing on their POAC certificate. They are subject to pay the CPOA Improvement fee.

7. ID & MARGINAL REGISTERED POAS - **Delete entire section.**

8. COLOUR NECESSARY TO SHOW - **Delete entire section and replace with:**

COLOUR FAULTS

Any certificated pony which shows Pinto colouration, excessive white markings or roan colour shall be screened from the show prior to its beginning.

9. MEASURING - **Delete entire section and replace with:**

The Show Committee shall announce the time and place of measuring ponies at a show. The Show Committee shall have at least one CPOA approved official for measuring purposes at events where CPOA classes are being held. All Ponies that show in Halter classes that are between the ages of 3 and 6 years of age must be officially measured at the first show they attend each year to determine which height division they fit for the current year. The Pony will be issued a temporary height card indicating its official height class for the rest of the year. The card must be shown will need to be available to be shown at all shows, or photocopied and sent in with entries, for CPOA point approved classes that are split by height divisions. If the card is lost or destroyed it can be replaced at a fee of \$10.00.

The Show Committee has the right and the obligation to measure any pony, prior to the start of a show, that is under the age of 7 years, that the Committee suspects is over the height of 14.2 h.h. (58 inches) at the highest point of the withers or under the height of 11.2 h.h. (46 inches). All CPOA's over the age of 6 have their official height marked on their certificates and this height shall be considered sufficient by the Show Committee.

The pony of questionable height must be measured by at least one CPOA approved Show officials with a proper approved measuring stick with a level on a smooth flat surface. A pony of questionable height may be measured by an approved official no earlier than 7 days prior to the show or at the latest before the show commences.

Any pony measuring over 14.2 h.h. (58") or under 11.2 h.h. (46") must be reported to the CPOA by written statement by the Show Committee. The Pony will be automatically protested upon the receipt of the statement which must be filed with the CPOA office at the time the show results are submitted.

10. OFFICIAL HEIGHT CHART - **Delete entire section.**

11. CLASSIFICATION OF PONIES - **Delete entire section and replace with:**

Small – 12.2 h.h. (50 inches) and under.

Medium – over 12.2 h.h. (50 inches) and not exceeding 13.2 h.h. (54 inches).

Large - over 13.2 h.h (54 inches) and not exceeding 14.2 h.h. (58 inches).

If a pony is entered in the wrong height class it must be re-entered in their appropriate classes.

Be sure that ponies entered in a Novice Pony Class have not placed first in that class at an approved CPOA show previous to the time the entries close in that particular class.

12. WITHDRAWING PONIES FROM A SHOW, FORFEITURE OF ENTRY FEES & WINNINGS - **Delete entire section and replace with:**

Every pony in any show found eligible to show by the Show Committee must show upon entering its designated class or classes unless excused by the Show Committee for good cause or forfeit all entry fees and winnings in said show.

A pony shall be excused by the ring person, the judge or the Show Committee if deemed necessary to protect the health or safety of the pony or rider, or for safety to other riders or ponies and no refund be given.

A full refund will only be given if a veterinarian's certificate or a doctor's certificate is presented prior to the commencement of the show. The Show Secretary in any such event must be immediately informed.

13. AGE OF PONY - - **Delete:** "For registration, show and sale purposes a" and insert "A"

14. SURGICAL ALTERATIONS AND IMPROPER POSING - **Delete 2nd paragraph and replace with:**

Tail setting by cutting or "nicking", or ear trimming (meaning actual cutting of the ear), are not permitted. Any pony known or found to be so altered shall be barred from showing in any CPOA breed class.

15. SELECTING A JUDGE - **Delete entire section and replace with:**

If CPOA approved shows are to be judged by someone not listed on the Equine Canada approved judges list, he must be an approved breed or provincial Horse Council approved judge carded within the last two years. Junior judges are acceptable. Please send his name and address and a copy of his approval card to the Home Office for approval. An Official Show Rule book will be sent to all judges.

16. INSTRUCTION TO THE JUDGES

After: Judges are not to inspect ponies in barn or on grounds prior to show. **Insert:** Exception: If the Show committee requests, and the Judge accepts, a measurement of a pony of questionable height in the absence of a capable Show official.

After: The judge shall select the grand champion stallion, mare or gelding from the first place winners, the ring person shall take the second place pony in the class from which the grand champion has been selected and place it in line with the first place class winners, to be judged equally for the title of reserve champion stallion, mare or gelding. **Insert:** Geldings and Spayed Mares may not compete against breeding animals.

17. INSTRUCTIONS TO SHOW COMMITTEE - **Delete 1st paragraph and insert:**

If the pony has met the screening criteria its certificate number and height must be recorded by the Show Committee on the screening sheet and the pony shall then be accepted as a show entry. The Show Results and Judge's cards must be reported as advised by the Home Office. The Show Rules Committee recommends there be one person designated at each show where approved CPOA classes are held to record Show Results.

Delete Last paragraph and insert: A CPOA Improvement Fee of \$5.00 per pony per show for posting show points, providing judges' handbook and publishing show results in the magazine will be charged for each CPOA point approved show. The fee is to be sent with show results within ten days of the show date.

18. SHOW MANAGER - **after:** *e.g. If Cloverleaf barrels is offered he makes sure there are three barrels insert , starting equipment,, timers and timing equipment*

19. SHOW SECRETARY - **after:** The Show Secretary's responsibilities are to: **insert:** -Ensure ponies entered are eligible to show.

20. RING STEWARD - **Delete paragraph 2 and insert:** !It is suggested that when there are a lot of new people at a show they be given a warning that the equipment they wish to use is not acceptable rather than just disqualifying them. It is the duty of the ring steward to educate the exhibitors as to the specific rules, not just disqualify them.

21. RING PERSON'S RESPONSIBILITIES - **after:** Responsibilities are: **delete and insert:**

ËTo notify the judge when all ponies are present for each class.

ËTo be in charge of activity in the show ring in co-ordination with the announcer.

ËActs as mediator between judge and exhibitors.

ËAct on instruction from the judge,

ËMoves and places ponies as judge requests.

ËNot to allow exhibitors to crowd up in the show ring.

ËHe is selected to help the judge - not advise him, argue with him or criticize him.

22. GATE PERSON/WHIPPER-IN - **Delete 1st paragraph and insert:** The gate people are responsible for opening and closing the gate after each class so that exhibitors can enter or exit. The gate shall be closed at all times when the class is taking place. The gate people will make sure the gate is clear of spectators while a class enters or exits the arena. The show secretary should provide a list of all entries in each class including their show number and name so the gate people or whipper-in can advise entrants of their next class.

23. SCREENING COMMITTEE - **Delete and insert:**

Before Screening starts, the Screening person needs to inspect the show area for a flat, level location to measure ponies. The show

secretary will provide a list all of the pre-entered ponies that require screening on screening sheets. The screening person should make sure they have additional sheets to add those entering the day of the show. The Screening person/Show Secretary must check all Certificates to ensure the ownership on the certificate and the owner of the pony on the entry form are the same person; Stallion's Two years and Older must be checked to ensure both testicles are present; measure ponies that are not yet carded for the year; measure ponies that might be over 14.2 h.h. (58") and screen ponies that show excessive white/pinto markings. – See COLOUR FAULTS, Page 3.

Any pony wishing to compete in a CPOA Point Approved show or classes must show it's Official Certificate or a photocopy of the original showing both sides of the certificate at the time of screening or provide a photocopy with their entries. Ponies that require screening must have their certificate or photocopy available at the time of screening and ready to be given to the screening person at the time of screening and be deemed by the screening person to be correct in order for the CPOA to pass screening for the classes entered, show or show season. P.O.A.C. Inc. registered POAs may show on their P.O.A.C. Inc. certificates as long as they are correct in accordance with CPOA rules. They do not collect any national points with the CPOA Association unless they possess a CPOA Association Certificate and show on their CPOA certificate.

The screening committee must review certificates for: CPOAs full name and CPOA's Registered Owner's name. All CPOAs entered in a CPOA Point Approved Show must be entered in the registered owners name which must be the same name as the owner on the entry blank. The registered owner must be a member in good standing with the CPOA Association in order for his/her pony to collect points towards national awards.

CPOA's may be inspected at shows for registry purposes providing there is a National Inspector present who will take photos (if the owner doesn't have any), collect all fees, a completed application for the pony's certificate form and include a completed inspection form. The National Inspector will inform the show committee that, in his/her their judgment, the requirements have been met and the show committee may proceed to allow the pony to show. The National Inspector is then responsible to forward the necessary documentation and fees to the Home Office within 10 days of the show. The inspector's decision as to the certification of a pony is not final. This is decided by the Executive Secretary and/or the Board of Directors and their decision is final. If the pony is deemed unworthy of certification, the pony's placing shall be void. Any ponies that showed in classes with the voided pony will "roll up" to receive higher placings and points according to the judges cards when applicable.

POAs registered with the P.O.A.C. Inc. may be certified with the CPOA Association at the show as long as all necessary paperwork is filled out and the pony meets all the requirements to show in the same fashion as above but must include a photocopy of both sides of their P.O.A.C. Inc. certificate with all the CPOA required documentation.

24. REGISTRATION CERTIFICATES - **delete entire section.**

25. ID AND MARGINAL STATUS - **delete entire section.**

26. TENTATIVE STATUS - **Delete entire section and replace with:** Tentative certificates are required to show any pony that is 5 years and under. When a tentative certificated pony reaches the age of 6, it must be updated to permanent status by the end of the year or it will be recorded as Void-NRO in the Association's Book of Record.

27. CHECKING THE POA - **Delete entire section and replace with:**

After checking the pony's certificate/photocopy the CPOA is checked as to its sex to determine if it is a stallion, mare, gelding or spayed mare. A stallion two years and over must be inspected to verify he has two testicles descended into the scrotum. If a Stallion is two years or older and does not have both testicles present, the Screener must inform the owner that the pony is ineligible to show. Further, the Screener must inform the CPOA Home Office of their findings within ten days after the show in writing sent via a signed letter by mail, fax or e mail.

If the CPOA's certificate says the pony is a stallion when in fact it is a gelding, in order to show in the show the registered owner must provide the Screener with the original registration certificate and a letter stating the CPOA was gelded and the approximate date this occurred which the Screener must send to the Home Office within ten days of the show. The Screener may then allow the pony to show. NOTE: A spayed mare cannot show in a Mare class but must be shown in the Gelding/Spayed Mare or Altered CPOA classes.

Once the POA has passed all the above criteria he is deemed to have passed screening.

28. CHECK LIST & TIME PLAN FOR RUNNING A POA SHOW - Section: Well Ahead

After: 6. Arrange and Book Arena and stabling. **Insert:** Check for washroom facilities etc.

After: 10. Arrange for Insurance, if required. **Insert:** *NOTE* All exhibitors must be current members of their local Horse Council.

29. On Completion of Competition (or next day) - **Delete 1st paragraph and insert:** Clean up. Finish all paper work. Pay all outstanding accounts. For Nationally Approved shows send all correctly tabulated results, and copies of tests, as well as original Judges cards and all other Official Show Results to the Head Office of the CPOA Association.

30. OFFICIAL SHOW RESULTS - **Delete entire section and replace with:**

The Official Show Results consist of:

X Original Judges Cards (the ones with the Judges signature on them) Photocopy's of original judges cards showing the judges signature are acceptable only in shows or fairs that offer CPOA classes in conjunction with an open show event or fair.

X Original Screening Sheets (supplied by the CPOA)

X CPOA Improvement Fee (\$5.00 per CPOA entered in the show)

X Printed out Show results for the CPOA News

X All Fees and Paperwork must be received by the head office with in 10 days of the date of the show.

31. HALTER. Section: TACK:

After: " Halters with stallion bits are" **delete:** "not"

After: Exhibitors dressed in English attire must use an English bridle (see English Tack), **delete rest of paragraph and insert:** "a plain halter or decorated English style halter. Tack and Attire may not be mixed."

32. POA HALTER CLASS SPECIFICATIONS - **Delete:** Only Tentative or Permanent registered POAs **and insert:** Only CPOAs with approved certificates...

33. BROODMARES - **Delete section and insert:**

Broodmares are defined as CPOA mares which have a foal in the current year. If a broodmare shows in the broodmare halter class it may not show in a different age division as well. The broodmare competes for Senior and Reserve Senior Champion Mare as well as Grand and Reserve just as any mare showing in halter. Full soundness is not required.

34. COLOUR CLASS - **Delete:** ID and Marginal registered POAs may not compete for a Colour award.

35. **After:** INDIVIDUAL CHAMPIONSHIP CLASSES **insert a new section:**

HOW TO CONDUCT A CHAMPIONSHIP HALTER CLASS.

FOR JUNIOR OR SENIOR CHAMPION:

The 1st and 2nd place ponies finishers in their regular halter classes are required to come back to be judged for Junior or Senior Champions and Reserve Champions or forfeit their placing and national points. Only the eligible ponies will enter the arena and will line-up as follows: The 1st place winners will stand in the front line "side by side" allowing plenty of room for safety and the Judge(s) and ring crew to walk between and around the ponies. The 2nd second place ponies will line up "behind" (head to tail) the pony that defeated them in their regular halter class, creating a second tier and allowing room for safety of the Judge and ring crew to pass. The Judge will choose a Champion from the front row. Once the Judge has chosen the Champion the handler of the Champion will be asked to move the pony from the line to an area in the arena that is about 20-30 feet away from the rest of the ponies. At this time, the second place pony will be moved by its handler up to the front line in the place vacated by the pony that has been chosen as Champion. The Judge can now proceed to select pick his Reserve Champion from the front line. Once the Judge's card has been given to the announcer the Champion and Reserve champion will be announced.

FOR GRAND AND RESERVE GRAND CHAMPION:

The Junior Champion, Reserve Junior Champion, Senior Champion and Reserve Senior Champion are required to come back to be judged for the Grand and Reserve Grand Champion Class. The Junior Champion and Senior Champion will enter the arena and line up side by side creating a front row allowing room for safety, Judge(s) and ring crew. The Reserve Junior and Reserve Senior Champions will line up head to tail "behind" the pony that defeated them in the Junior or Senior Champion Class, creating a second row, allowing room for safety, Judge(s) and ring crew. The Judge will choose a Grand Champion from the front row. Once the Judge has chosen the Champion the handler of the Grand Champion will be asked to move the pony from the line to an area in the arena that is about 20 - 30 feet away from the rest of the ponies. At this point, the Reserve Junior or Reserve Senior Champion pony will be moved by it's handler to the front line in the place vacated by the pony that has been chosen as Grand Champion. The Judge now proceeds to select his Reserve Grand Champion from the front row. Once the Judge's card has been given to the announcer the Grand Champion and Reserve Grand Champion will be announced.

36. GROUP HALTER CLASSES - **delete paragraph and insert:** Group classes consist of Get of Sire, Produce of Dam, and Mare with Foal at Foot. They are to be judged 75 percent on conformation and 25 percent on uniformity of the animals. No discrimination should be made by the judges on age of the ponies. Only certificated CPOAs are eligible for these classes but sire or dam may be of any breed. In Get of Sire and Produce of Dam classes, the sire or dam shall not be shown.

38. GET OF SIRE - **delete paragraph and insert:**

Sire may be a alive or deceased. Three POAs with Canadian or P.O.A.C. certificates of any age having the same sire are to be shown. May be out of different dams. Can be of combined ownership. Sire is not to be shown

39. PRODUCE OF DAM - **delete paragraph and insert:**

Dam may be alive or deceased. Two POAs with CPOA or P.O.A.C. Certificates of any age having the same dam are to be shown. May be by different sires. Combined ownership permissible. Dam is not to be shown.

40. MARE WITH FOAL AT FOOT - **delete paragraph and insert:**

The intent of this class is to recognize mares which produce foals which are better than themselves. Consequently both the mare and foal are judged. It is also the only class offered at CPOA shows which allows mares which are not CPOAs to show, provided they have a foal at foot that has it's CPOA or P.O.A.C. Certificate and which passes screening. This is a non-point class.

41. **After:** MARE WITH FOAL AT FOOT section: **insert a new section:** "AT LIBERTY" HALTER CLASSES

AT LIBERTY HALTER: This class is meant to show the suitability of CPOA's to the Sport Disciplines. The "at liberty" class shall be judged with 10 percent for each of the following categories: conformation, type, shoulders and withers, top-line and quarters, front legs, hind legs, correctness of movement, carriage, elasticity and manners. The total score will determine the animal's placing. Ties in overall scores will be separated by individual scores on the trot. If a "tie" still exists then the gallop score will be used to separate them followed by the conformation score. If a "tie" still exists both the animals will be awarded the higher placing and the point value will be split between the two. For example, if 2 animals finish 3rd and can not be separated they will be awarded 3rd place ribbons. If a 3rd is worth 4 points and a 4th is worth 3 points the animals will receive 3.5 points each. The next placing in the class would be 5th.

Class Routine: Ponies will enter the arena one at a time. They should be well groomed and show ready. The handler walks to the judge, stops and sets up for the conformation inspection. After the inspection the judge will signal the handler begin the course. The handler proceeds to the first cone laid out to indicate a triangle and starts at the walk heading clockwise. When the handler reaches the starting point he/she will trot around the triangle of cones in a clockwise direction. The judge may request another walk or trot on the triangle. When the triangle portion is completed the pony is halted and stood up to show manners and control. The judge will ask for the pony to be turned loose to be judged "at liberty" at the trot and canter. The handler may carry a lunge whip or shaker to encourage to pony to move at the desired gaits in both directions of the arena. Others may enter the arena to help in this phase. When judging is complete the ring person will thank the handler who will catch the pony. In the event that a free jump class is offered or for ponies three years and older the handler will proceed to the chute to jump. If free jumping is not offered the handler and pony will leave the arena. When all the ponies in each section have been judged they will all re-enter the arena and line up for the "critique" by the Judge. Each pony will step forward when called, hear the critique and final score then return to the line.

The critique will be complete as follows: The Judge will start with the pony scoring the lowest in each class beginning with weanlings, then yearlings followed by two-year-olds. When all two and under ponies have been critiqued and placed the 1st and 2nd place will receive Junior Champion and Reserve Junior Champion respectively. The same procedure will be followed for the three and older division and all Small, Medium and Large ponies will be critiqued then the two highest scoring ponies from the small, medium and large sections will be awarded Senior Champion and Reserve Senior Champion in their sex division. The Grand Champion and Reserve Grand Champion will then be announced based on the highest scores received by the Junior and Reserve Junior Champion and the Senior Champion and Reserve Senior Champion.

Tack: The pony can be shown in a halter or a bridle with no reins, but the lead shank should be quickly and easily detachable.

Attire: Attire is designed to benefit movement and judging. Light coloured pants are to be worn so as not to interfere with the Judge's view of the pony's legs. These should be white to cream coloured. The shirt, sweater or jacket can be of any colour or style that is clean and neat, with long or short sleeves but not a Tee-shirt. Shoes should be comfortable - sneakers or boots are acceptable. Hair must be neat and tidy - long hair should be restrained in a hair net or pony tail. Hats, whips and shakers are optional. Entry number to be worn on the handler's back clearly visible at all times.

Equipment needed: 3 cones or lime to mark a triangle. Triangle can vary in size from 20 - 40 feet depending on the size of the arena.

42. After At Liberty halter **insert:** FREE-JUMP PROTOCOL ; Only ponies three years of age and older can participate in a "Free-Jump" class. The class is designed to judge the CPOAs actual ability over fences and is judged 10% on correctness of movement, carriage and elasticity, approach to a fence, style over the fence, neatness of front legs, neatness of back legs, landing, balance, attitude and manners and general impression.

Class Routine:

A team of one supervisor and four assistants carefully selected (to be arranged by hosts or owners) and suitably equipped with longeing whips will be in the ring. The supervisor will be in charge of the entire process. Only one pony and handler will be permitted in the ring at a time.

Equipment needed: A chute which is to be constructed with side rails to form an opening of about 4 feet wide on one side directly behind the first two jumps to allow for the pony to enter for observation and later to station a person to encourage the pony over the jumps. To construct the chute and catch pen, 20 standards, 6 wings and 30 poles are needed for proper setup.

The handler will first walk the pony into the chute at the provided side opening to allow the pony to see and familiarize itself with the chute and obstacles. Unless otherwise directed by the Judge, each pony will be allowed three jumping runs through a triple combination jumping chute contained by side rails the entire length of the chute. The first element will be crossed poles, with the ends in the standards at 30 inches of height, and a ground pole in front (Figs. 1a and 2a). The second element, about 20 feet from the first element (measured from the back of the first element

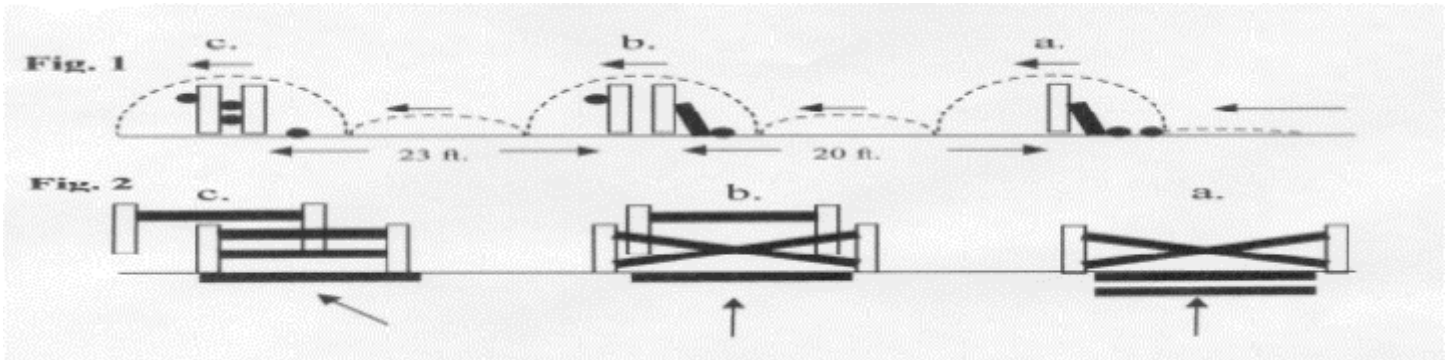

to the front of the second) will be similar to the first but with a horizontal rail, also at 24 inches of height, immediately behind the crossed poles (Figs. 1b. and 2b). The third element, approximately 23 feet from the second, (measured from the back of the second element to the front of the third) will be an oxer (Figs. 1c and 2c), 30 inches high, with a spread of 24 inches, which will also have a ground pole in front. This jump can be raised in 3" increments up to a maximum of 36", and the spread increased accordingly, for the second and third runs, depending on the height of the pony. The front rail on the third oxer will be placed about 6 inches lower than the back rail to allow ramping of the oxer. A catch pen will be constructed after the final jump to contain the pony after each run. This should be constructed with standards and poles and should be approximately 25-30 feet long and the width of the chute. For each run, the pony will be trotted in hand up to the first element. A 36-inch length of plain nylon cord is the best release cord and will be run through the near snaffle ring from which the reins have been removed. One end of the cord will be released to allow the cord to slip out about 8 to 10 feet in front of the first element as the pony is sent down the jumping chute.

Tack: The pony can be shown in a halter or a bridle with no reins. The nylon cord should be quickly and easily detachable.

Attire: Attire is designed to benefit movement and judging. Light coloured pants are to be worn so as not to interfere with the Judge's view of the pony's legs. These should be white to cream coloured. The shirt, sweater or jacket can be of any colour or style that is clean and neat, with long or short sleeves but not a Tee-shirt. Shoes should be comfortable - sneakers or boots are acceptable. Hair must be neat and tidy - long hair should be restrained in a hair net or pony tail. Hats, whips and shakers are optional. Entry number to be worn on the handler's back clearly visible at all times.

42. After FREE JUMPING PROTOCOLSPAYED MARES **insert a new section: "IN HAND" Halter Class**

In Hand Halter Classes are conducted in the same fashion as regular Halter classes with two exceptions. When the Judge asks for a trot it shall be a "brisk" trot and attire for this class is the same as for the "at liberty" class.

43. PERFORMANCE, Section: RULES AND SPECIFICATIONS: **delete Paragraph 7 & 8 and insert**

The term "leadline" applies only to 8 and under Equitation unless specified Pleasure by the Show Committee.

In Pleasure and Equitation classes, English and Western style riding should not be combined.

44. TWO AND UNDER LUNGE LINE PLEASURE - Delete last paragraph and insert:

CPOAs will enter the arena one at a time or are lined up at one end. One at a time they will go to a designated area and show on the lunge line. The ponies will have two minutes to show at the walk, jog/trot, and lope/canter both ways of the ring. The ring person will use a timer and will announce when one minute is complete as well as when two minutes are over. Following the individual work splint boots must be removed if used. The handler has the option to switch to a show lead at this time, if desired. Ponies will then be required to line up for the halter portion of the class, which is judged on the conformation of the pony.

45. TWO AND UNDER LUNGE LINE PLEASURE , Section: Tack: Delete No. 3. & insert: 3. Head excessively low for more than 3 strides.

46. TRAIL CLASS - **delete paragraph 8 and insert:**

Ponies must not be required to work on the rail. The course must be designed, however, to require each pony to show three gaits (walk, jog, lope) somewhere between obstacles as part of its work and this will be scored as a maneuver. At the discretion of the show committee, 8 & Under riders may be asked to show at a walk and trot only.

47. LONG LINE TRAIL - **Delete 1st paragraph and insert:** Long Line Trail is open to yearling, two and three-year-old CPOAs of any sex. This class is offered as a means of training our future Trail trail/obstacle CPOAs.

48. COSTUME DIVISION - **Amend 2nd line of 2nd paragraph to read:** The class is to be judged at the walk and/or trot only, both ways of the ring.

49. PROTESTS AND CONTROVERSIES - **delete 1st paragraph and insert:** Any matter of controversy (protests, complaints, etc.) sent to the Executive Secretary for the National Hearing Committee or the CPOA Association Board of Directors may be printed in the CPOA Association Official Magazine. Only members in good standing of the CPOA Association can submit a protest.

50. **Delete:** PROTESTS CHALLENGING THE REGISTRATION, HEIGHT, COLOUR, OR OTHER STATUS OF A POA.

The procedure for handling this shall be in accordance with Article IX of the CPOA Bylaws as follows:

Sec. 1. An official protest in writing and signed by the protestor must be filed with the Executive Secretary to challenge the registration or other status of any pony.

Insert: PROTESTS CHALLENGING THE CERTIFICATION, HEIGHT, COLOUR, OR OTHER STATUS OF A POA.

The procedure for handling this shall be in accordance with Article IX of the CPOA Bylaws as follows:

Sec. 1. An official protest in writing and signed by the protestor must be filed with the Executive Secretary to challenge the certification or other status of any pony.

51. PROTESTS CHALLENGING THE CERTIFICATION, HEIGHT, COLOUR, OR OTHER STATUS OF A POA.

Delete: Sec. 3. **and insert:**

Sec. 3. The protest must be accompanied by a \$500.00 protest fee in order to be heard; provided, however, if the protest is filed by a chairman of a show committee or the chairman of a sale committee, or by any member of the National Board of Directors, there should be no protest fee. If the protest is upheld \$250.00 of the protest fee will be returned to the protestor and the remaining \$250.00 retained by the CPOA Association to defray expenses. If the protest is not upheld, \$250.00 of the protest fee shall be delivered to the owner of the protested pony and the remaining \$250.00 retained by the CPOA Association to defray expenses.

Sec. 5. **After:** "right of transfer" **delete:** "and registration"

Sec. 7. **After:** "official measurement card," **delete:** "registration"

Delete: Sec. 8. **and insert:**

Sec. 8. The registered owner or owners are entitled to appeal an adverse decision of the inspection committee within 30 days from the inspection date by filing a written notice to that effect with the Executive Secretary with a \$750.00 appeal fee. The Executive Secretary shall return \$500.00 of the appeal fee to the owner if the inspection committee is over-turned on appeal. The appeal fee shall be retained to help defray the cost of appeal if the inspection committee is upheld on appeal.

Sec.12. **After:** " measurement card or " **delete:** "registration"

52. PROTEST INVOLVING A SHOW OR SHOW RULES - **delete section c and insert:**

c) The protest must be accompanied by a \$500.00 protest fee in order to be heard. If not filed at the show, a protest must be postmarked within three days, including the date of the show, and sent to the chairman of the show.

Delete section e and insert: e) If an appeal is made after the Show Committee's decision, the \$750.00 protest fee shall accompany the appeal to the National Hearing Committee. \$250.00 of the protest fee will be given to the person upheld by the final decision.

Delete section h and insert: Sec. h) Protests for causes other than height and colour and other matters not concerning the certification status of the pony shall be handled in accordance with the rules of the show in progress.

Delete section g and insert:

g) If a pony has been properly entered and passed by the screening committee and the height and colour approved by said committee, and the show is in progress any protest must be submitted in writing, along with the \$500.00 protest fee. The exhibitor or owner will be informed of such protest but the show shall progress normally. Disposition of the grievance shall take place after the show by the Show Committee. This DOES NOT apply to ponies which have a Permanent Height Card.

53. PROTESTS OF A PERMANENT HEIGHT CARD - **delete entire section**

2005 MEMBERSHIPS ARE PAST DUE!

If you have not renewed your membership this will be the last newsletter you receive.

FOALS OUT AND ABOUT

Don't forget to tell us about your new foal and let us brag about it for you!

1. Bay filly with a blanket owned by Lee & Natasha Pusch of LNP Spotted Ridge Stable, Maple Ridge, BC
Sire: LJ's Draaken - E-T-2006, CPOA
Dam: Frosty's Ladybug - T-FI-83, CPOA

